

# Installation Guide

Applicable Models: TS 1000/2000 Pro series tripod turnstile

Version: 2.0

Date: March. 2020

# Chapter 1 Installation

## 1.1 Installation conditions

When installing the tripod turnstile against the wall, please reserve at least 100 mm space for opening the cover. As shown in Figure 1-1.

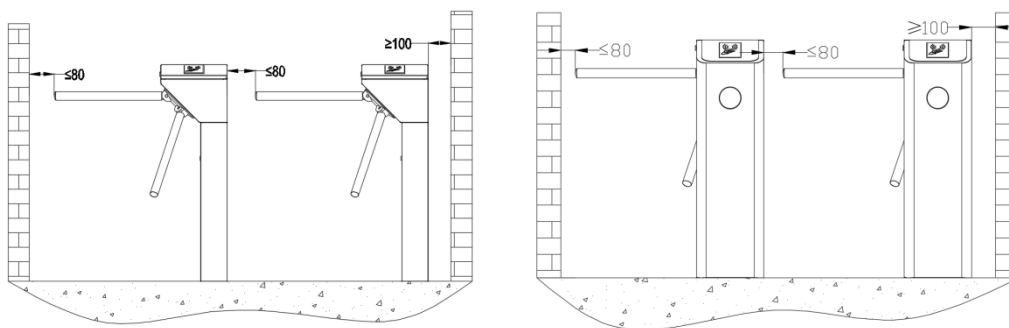

Figure 1-1

## 1.2 Cabling

Power supply and communication wire suggested to be deployed underground then into the cabinet of device.

## 1.3 Drilling holes

Drill holes based on the locations of the screw holes.

## 1.4 Fix the device

Fix the device on the ground by 4 expansion screws.

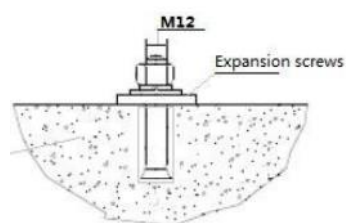

**Note:** The tripod turnstile must be connected to the Ground (earth), there is a wiring interface near the power switch.

## Chapter 2 Installation Notes

In order to keep the arm won't be damaged during the transportation. The arm wasn't install on device.

1. Put arm kit into the hole of cabinet, make sure the screw holes match with mechanism core, then tighten 3 hex screws, as shown in Figure 2-1.

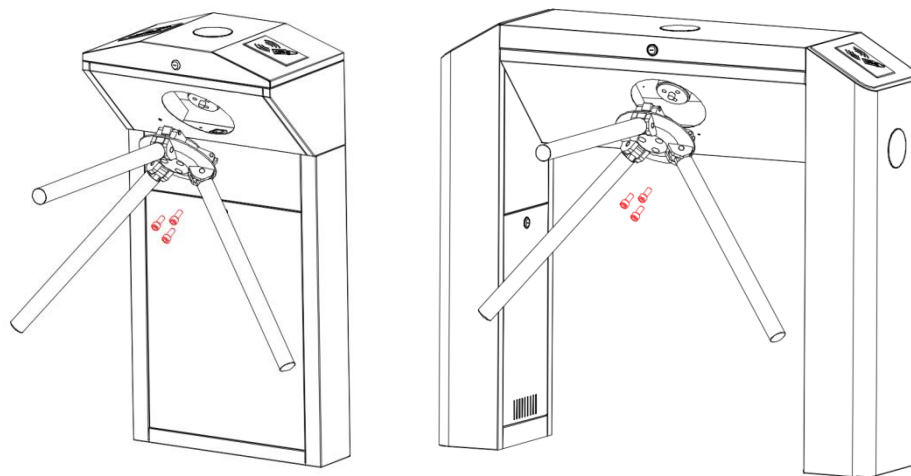

Figure 2-1

2. Please make sure that the power requirements are strictly met to avoid permanent damage to the unit. Input voltage: AC 100~120V /200~240V.
3. Power on and wait 30s for the tripod turnstile to finish the self-check program
4. Lift the arm manually, as shown in Figure 2-2

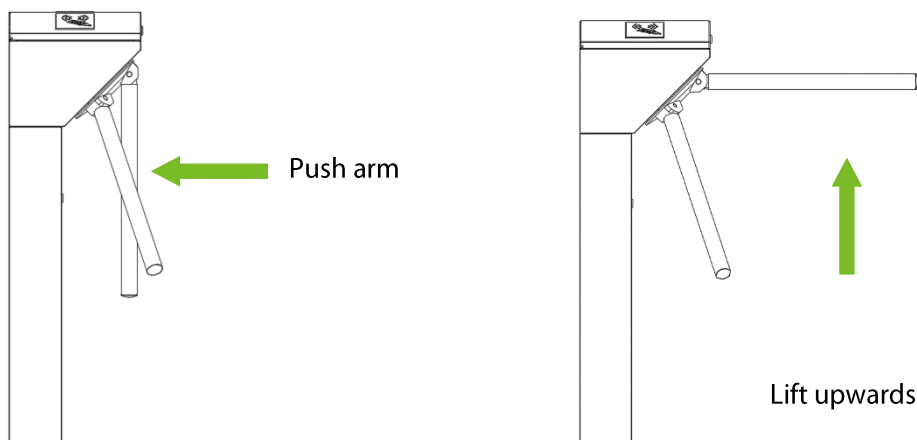

Figure 2-2

Note: If the arm can not be lift, please push the arm to close to cabinet direction first, then lift the arm manually.

# Chapter 3 Control Board Introduction

## 3.1 Function description of the turnstile control board

If you are using standard device that without RFID or Fingerprint reader, you need to connect access control system to the main board, please check the content in this chapter carefully.

Turnstile control board's diagram as shown in Figure3-1

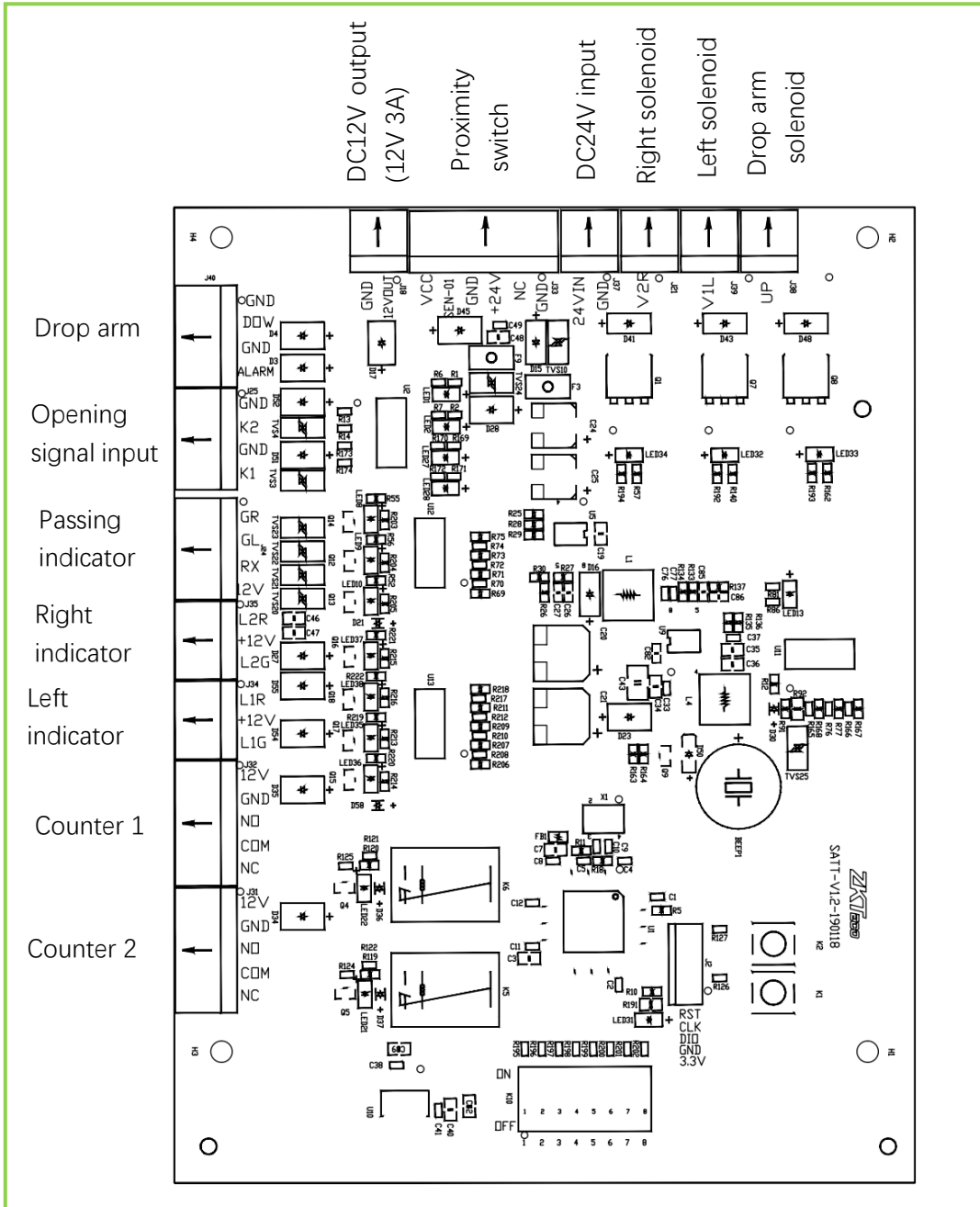

**Note:** The third party access control system lock relay trigger time should be 1

second or less than 1 second.

### 3.2 Connection Diagram of the Access Controller

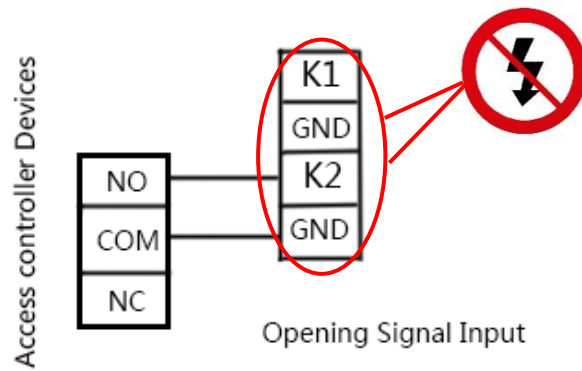

**Note:** The lock relay duration of access controller device needs to be set to 1s. Forbidden using electrically charged objects to connect to the port of Opening Signal Input, otherwise will damage the control board.

## Chapter 4 Maintenance

### Forming maintenance consciousness

The tripod turnstile needs to be maintained regularly and repaired once it is damaged. It is recommended that warning signs being placed at conspicuous positions for prompting passers-by to pass in a proper way and in good order. Reasonable maintenance consciousness helps to guarantee long-term usage of the tripod turnstile.

### Regular maintenance

Cleaning and protection liquid dedicated for stainless steel are recommended to wipe the outer shell of the equipment regularly. The tripod turnstile used outdoors or in an environment with lots of dust must be maintained once a year at least, for example, clean up the dust and add appropriate lubricating oil to Disk Wheel. Note regular maintenance should be performed after power off the equipment, as shown in Figure4-1.

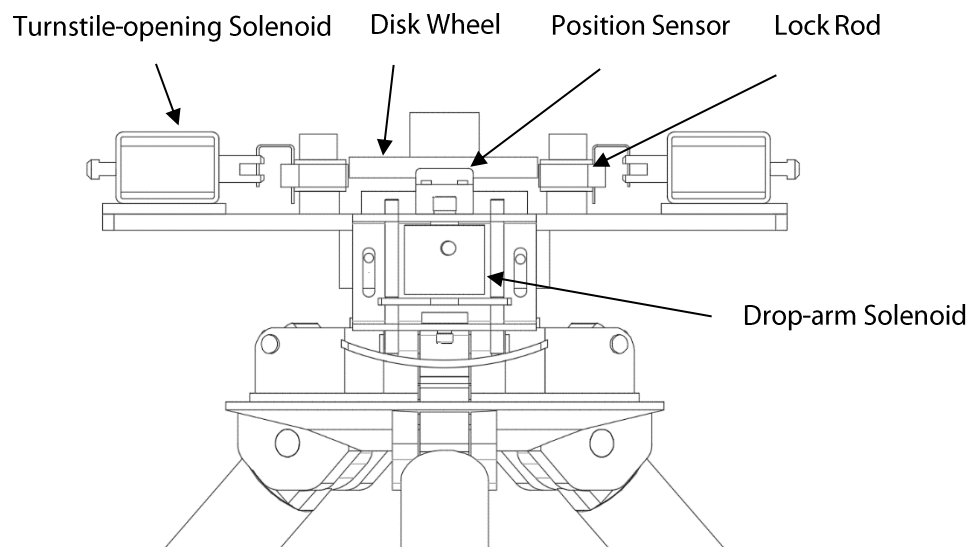

Figure 4-1

## Chapter 5 Troubleshooting

Symptom	Troubleshooting
The indicator is not lighted when the equipment is powered on.	It may be caused by the power supply or circuit. Check whether the connection cable and power cable between are damaged, or the wiring is loose.
The arms of the tripod turnstile cannot be lifted manually after the equipment is powered on.	It may be caused by the problem of relative components or drop-arm solenoid. Check whether the drop-arm solenoid is operating, and check the work status of the solenoid, as shown in Figure 4-1.
The tripod turnstile does not open after authentication.	It may be caused by lack of permission or a circuit problem. <ol style="list-style-type: none"> <li>1. Check whether the user has the permission to open the turnstile.</li> <li>2. Use a multimeter to check whether the NO and COM ports of the access control system has a relay signal output.</li> <li>3. Short-circuit the ports "K1, GND" and "K2, GND", if the turnstile is successfully opened, it would be the problem of controller.</li> </ol>
The turnstile allows people continue passing one-way side during the use.	<ol style="list-style-type: none"> <li>1. Check the Turnstile-opening Solenoid</li> <li>2. Check the access controller 'Lock driving duration', whether set to 1s.</li> <li>3. Check whether the Turnstile-opening solenoid is operating and check whether the Turnstile-opening solenoid is stuck, as shown in Figure 5-2.</li> </ol>